

# Functions & icons of plus 2 way remote unit

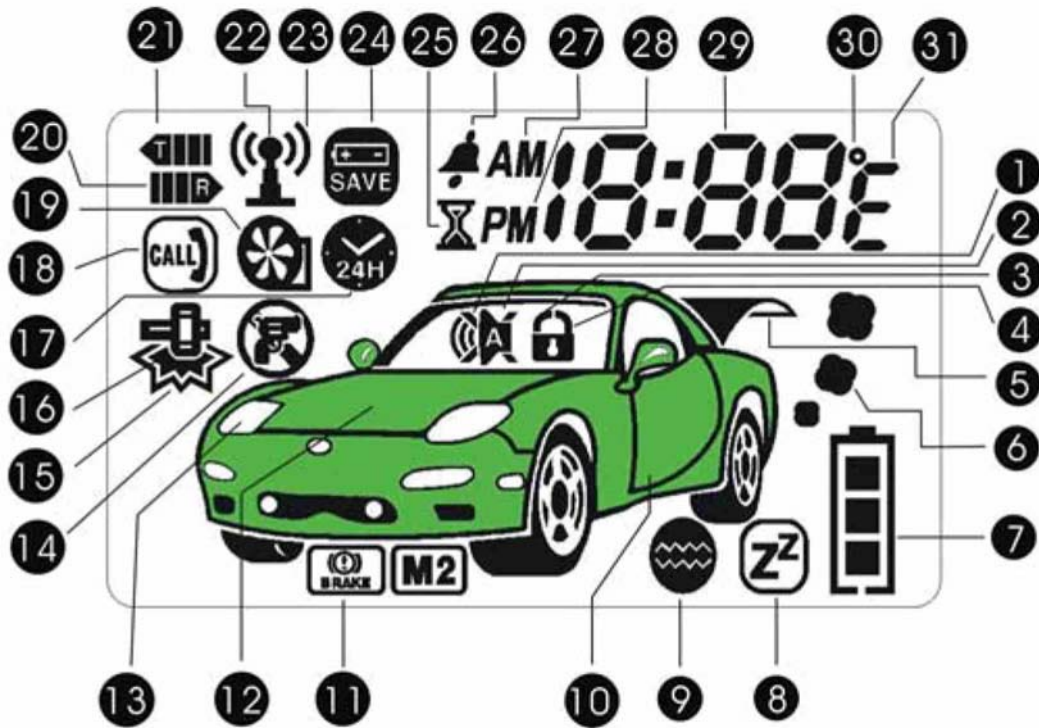

1. Audio alert mode
2. Mute alert mode
3. Lock
4. Unlock
5. Trunk release
6. Engine run
7. Remote's battery status
8. Valet mode ON
9. Vibration alert mode
10. Door open
11. Un-lodged hand brake indication
12. Hood open
13. Parking light indication
14. Anti-hijack activated
15. Shock sensor light trigger
16. Shock sensor heavy trigger
17. Daily auto start ON
18. Page-out transmitting
19. Temperature-auto start ON
20. Reception circuit at standby
21. Transmission circuit at standby
22. In-range indicator
23. Remote unit's transmitting
24. Power save mode
25. Count-down timer mode
26. Alarm clock mode
27. AM time mode
28. PM time mode
29. Hour, minute indication
30. Car's interior temp.
31. Celsius / Fahrenheit mode

## REMOTE CONTROL QUICK OPERATION GUIDE

Function mode	Sign represents button	Mark on button	Car or system situated
Lock/Arm	【 I 】		Ignition off
Arm at shock sensor bypass-ON	【 I + IV 】	+	In arm
Unlock /Disarm	【 I 】		Ignition off
Channel # 3 Hold	【 I 】 Hold	Hold	Any time
Engine start ON/OFF	【 II 】		Ignition off
Change engine runtime	【 I + II 】	+	Engine running
Check remaining engine runtime	【 I + II 】 Hold	+  Hold	Engine running
Remote temperature check	【 III 】		Any time
Trunk release (Channel # 1)	【 III 】 Hold	Hold	Any time
Siren ON/OFF	【 IV 】		Ignition off
Channel # 2 Hold	【 IV 】 Hold	Hold	Any time
Car search / locator	【 III+IV 】	+	Any time
Remote Panic	【 I + III 】	+	Ignition off
Remote anti-hijack ON	【 I + III 】 Hold	+  Hold	Ignition on
Remote anti-hijack OFF	【 I 】 Hold 【 I 】	Hold	Ignition on
Temp-controlled auto-start OFF	【 II + III 】	+	Ignition off
Temp-controlled auto-start ON	【 II + III 】 Hold	+  Hold	Ignition off
Daily auto start-time OFF	【 II + IV 】	+	Ignition off
Daily auto start-time ON	【 II + IV 】 Hold	+  Hold	Ignition off
Valet mode OFF	【 II + III + IV 】	+  +	Ignition off
Valet mode ON	【 II + III + IV 】 Hold	+  +  Hold	Ignition off





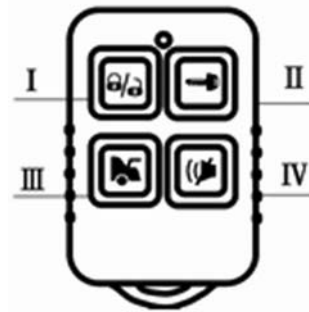



2 way remote



1 way remote

Function	Page
1 Door Lock/ arm -----	04
1.3 Window auto roll up -----	04
1.4 Defective zone bypass -----	04
2 Door unlock/disarm -----	04
2.3 Dome light -----	04
2.4 Security diagnostic report -----	04
2.5 Auto relock -----	04
2.6 Door lock/ unlock upon ignition -----	04
3 Auto arm or with lock upon closing Last door -----	04
4 Door Lock/ unlock -----	05
5 Remote engine start for auto gear car -----	05
6 Remote engine start for manual gear car -----	05
7 Remote control run time with status check -----	06
8 Remote engine shut off -----	06
9 Arm mode with engine running -----	06
10 Turbo engine timer -----	07
11 Immobilize mode upon ignition OFF -----	07
12 Remote temperature start ON/ OFF -----	07
13 Daily auto-start time ON/ OFF -----	07
14 Remote Temperature/ Status check -----	08
15 Active channel # 1 for release trunk -----	08
16 Remote siren/ horn alert ON/ OFF -----	08
17 Active channel # 2 -----	09
18 Active channel # 3 -----	09
19 Car locator/ search -----	09
20 Shock sensor by pass -----	09
21 Alarm mode & warn away -----	09
22 Remote Panic -----	10
23 Switch-controlled anti-hijack at standby -----	10
24 Remote or switch-controlled anti-hijack -----	10
25 Remote valet ON/ OFF -----	10
26 Page-out call -----	11
27 Programmable function by over-ride switch -----	11
28 Manual ARM and DISARM -----	11
29 How to learn codes of the remote transmitter -----	11
30 Hopping code transition -----	12
31 PIN Switch test for L E D -----	12
32 Dash LED status indicator -----	12
33 Power save mode of transmitter -----	13
34 Low battery indicate -----	13
35 Out-of-range indication -----	13
36 Programming of remote control unit -----	13

## 1. Door Lock/arm

1. Off the engine, close all car doors assuring all hood and trunk are closed and handbrake is pulled up.
  2. Press and release **【 I 】** siren chirps once with 2 flashes, the car door is locked and system enters arm mode.
  3. Window auto roll up : After the main system enters arm/lock, it will auto roll up the electronic window [an accessory is require for the function]. [RF program table]
  4. Defective zone bypass: In the case that car’s siren lone chirps 4 times or the remote unit sounds alarm, the main system detects a defective zone like any door not yet closed. (The remote will shows which trigger on LCD). The system will automatically bypass the defective zone and enter arm mode. After the defective zone is corrected, the system enters full arm mode.
- 1 The remote unit has the following responses.
5. If the main system is in audible alert mode, the remote LCD shows up    with melody sound.
  6. If the main system is in mute mode, the remote LCD shows up    with melody sound •

## 2. Door unlock/disarm

- 1) To activate this function, the car must be in the lock/arm mode.
- 2) Press and release **【 I 】** : the main system will unlock the door with 2 flashes of parking light.
3. **Dome light** : After the main system enters disarm/unlock or while in arm mode, if the alarm is triggered, the dome light will automatically turn ON. This can illuminate the car’s interior for owner’s checking need and is also a warning against theft. [RF program table]
4. **Security diagnostic report** : When remote disarm .if siren chirps 4 times or remote unit makes 4 buzzer sounds, there had been some zones being triggered. [The triggered zones will appear in the remote LCD].
5. **Auto relock** : If the door is not opened within 30 sec after it is unlocked by the remote unit, the main system will automatically lock/arm itself.
6. **Door lock/unlock upon ignition**
  - 1) In disarm/unlock into the car; when the ignition key is turned to “ON” all the car doors will immediate or after 10/30sec. auto lock. [RF program table]
  - 2) Before leaving the car, when the ignition key is turned to “OFF” with the key, all the car doors will unlock.

## 3. Auto arm or with lock upon closing Last door



1. Ignition must be off.
2. The automatic arm or with door lock will be activated with warning siren chirp when 10 sec countdown initiates from the time last car door is closed. [RF features programmable]
3. How to disable auto arm function
  - 1) If the car door is opened while the ignition is ON

- 2) The door close twice this function will disable.  
Note : If system installation on manual gear car and programmed to safe mode the auto arm function becomes ineffective.

1 If this function is standby or active the remote LCD show refer icon 4.

#### 4. Door Lock/unlock

- 1) While the engine is running and at the same time the ignition key at “ON” position.
- 2) If **【 I 】** is pressed and release each time; the main system will automatically lock /unlock car door with confirmation by its parking light flash

1 The remote LCD shows  when the door is unlocked and shows  when the door is locked





#### 5. Remote engine start for auto transmission gear [Refer to item 6 for manual transmission gear mode]

1. Press and release **【 II 】** To start engine or shut down the engine. The main system with 3 parking light flashes when the engine is started
2. Remote engine start can with auto arm/lock or not [ RF program table ]
3. Remote engine start cannot be done under such abnormal conditions.

- 1) The gear is not in its ‘P’ or ‘N’ position
- 2) Ignition key is turned on
- 3) Hood is opened
- 4) Handbrake is not secure.

5) In this case the remote LCD shows up .

1 The remote LCD responses refer icon 5.as below :

- 1) During the 1<sup>st</sup> stage: The remote LCD shows up the current status along with  during the pre-starting stage and the melody sound
- 2) During the 2<sup>nd</sup> stage: When the engine is started, the remote LCD shows up  icons along with engine’s preset run time for example  and s melody sound.
- 3) When the preset run time expires the engine will automatically shut down. [The remote LCD will show  when the last remaining 1 min begins] . The remote LCD shows  at the moment of engine shut-off and disappears.

#### 6. Remote engine start or shutdown on manual gear car.

For the manual car, there are 2 operation choices (A) and (B) for remote engine start. Be sure to follow the instruction by your installer.

Note:

- 1) If system install on manual gear car the last door close auto arm function becomes ineffective.
- 2) If system install on manual gear car and programmed the turbo function becomes ineffective.

##### A : SMART MODE

1. Let engine run by ignition key. Turn the ignition OFF while the engine is still running (Engine goes on running at this stage by system).
2. Then open the car door. Get off and re-close the door

3. Press and release **【 I 】** to make the system enter arm/lock and (Engine will automatically shutoff at this stage).

A) The system’s start is operable afterwards. If there is any mistake in the procedures. The system’s engine start is disabled.

B) If the system is disarmed as in “open the door and re-close”, engine start function is disabled.

4. Press and release **【 II 】** to remote engine start or shutdown.

#### B : SAFE MODE



1. Let engine run by ignition key. Press and release **【 II 】** then turn the ignition off while the engine is still running (Engine goes on running at this stage by system).
2. Then open the car door. Get off and re-close the door
3. Press and release **【 I 】** the system to make system enter arm/lock (Engine will automatically shut off at this stage).

A) The system’s start is operable afterwards. If there is any mistake in the procedures. The system’s engine start is disabled.

B) If the system is disarmed as in “open the door and re-close”, engine start function is disabled.

4. Press and release **【 II 】** to remote engine start or shutdown.

#### 7. Remote control run time with status check

1. Following the success of engine start; press both **【 I + II 】** simultaneously each time to allow 5 min engine run time with maximum up to of 20 min. The remote LCD shows up the runtime achieved. For example the LCD’s icon that shows  means engine run time is 15 min.
2. Following the success of engine start press and hold both **【 I + II 】** simultaneously to check the remaining engine run time. For example the LCD’s icon that shows  means the remaining run time is 8 min.

#### 8. Remote engine shut off

1. While the remote engine is running
  2. Press and releaser **【 II 】** : the engine shuts off with 2 siren chirps and 2 parking light flashes.
- 1 The remote LCD’s icon  will disappear but shows up the car’s status and sounds melody.

#### 9. Arm mode with engine running (this function only for auto gear)

1. Get the engine running from ignition key.
2. Press and release **【 II 】** button (the engine should still be running at this moment)
3. Take out the key from ignition and go out from the car.

4. After closing the last door (of course the trunk and hood should be closed before)
5. Press and release **【 I 】** button the system should be entering into "arm mode with engine running" automatically. The ignition input and shock sensor should be bypassed.



## 10. Turbo engine timer

1. The turbo timer is for the purpose to extend the engine's life (because the immediate shutdown of the engine is damaging to the engine). If the Turbo timer mode is chosen, engine will keep running for the duration of programmed turbo time when the engine is shut down by the ignition key. [RF program table]
  2. To clear this mod. Press and release **【 II 】** button or a stepping on the pedal brake.
- Note : If system installation on manual gear car and programmed to safe mode the turbo function becomes ineffective.

## 11. Immobilize mode upon ignition OFF

1. The system will automatically enter immobilize mode after 30 sec from the time when the ignition is turned OFF. The dash LED flashes indicate when ignition turns on at this mode. In such mode, engine start by the ignition key is disabled.
2. To clear this mode, press and release **【 I 】** button twice on the remote unit. Or turn the ignition OFF and then push the "1" time on the over-side switch [RF program table]

## 12. Remote temperature start ON/OFF







1. Temperature-controlled auto-start "ON": Press and hold both **【 II + III 】** to activate this function parking light flashes. Following this function's activation .The engine will start at the pre-selected temperature and begin running and automatically shut off when the pre-set run time expires.
  2. Temperature-controlled auto-start "OFF": Press and release both **【 II + III 】** to turn the temperature-controlled auto-start "OFF"
- 1 The remote LCD responses as below :
3. If temperature-controlled auto-start ON is activated: the remote LCD shows  to confirm this function is activated and the pre-set temperature icon like  appear on the display. The transmitter unit sounds melody.[ When the main system sensed - temperature, the engine start automatically].
  4. If temperature-controlled auto-start OFF is activated: the icon  disappears from remote LCD and the remote unit sounds melody.
  5. When such feature is programmed, the temp-controlled auto-engine run will go on for maximum 2 hours each time with a total 6 repeated cycles.

Note: The temperature can be programmed at -5°, -10°, -20°, -30° depending on your requirement for auto-engine run [RF features programmable].

## 13. Daily or 1 - 2 - 4 - 12 hours auto-start time ON/OFF

1. Daily auto-start time ON: Press and hold both **【 II + IV 】** simultaneously, the engine will auto-start at the real time of entry beginning from the next time with 6 flashes of parking

light and immediate engine running.

2. If within the 5 sec from the time engine is started, do the following to get different start-interval
  - 1) Press button  to get auto start with 1 hour interval between engine starts the LCD will show 1
  - 2) Press button  to get auto start with 2 hour interval between engine starts the LCD will show 2
  - 3) Press button  to get auto start with 4 hour interval between engine starts the LCD will show 4
  - 4) Press button  to get auto start with 12 hour interval between engine starts the LCD will show 12
3. Daily or hours auto-start time OFF: Press and release both **【 II + IV 】** simultaneously to turn this function OFF.
  - 1 The remote LCD responses as below:
  4. Dairy auto-start time ON: The remote LCD shows both  and sounds melody if this mode is chosen.
  5. Dairy auto-start time OFF: The  disappears from the remote LCD but sounds melody if this mode is chosen.

## 14. Remote Temperature/Status check

1. Press and release **【 III 】** to remote check the interior temperature and the current status of car. Parking light flashes 3 times.
    - 1 The remote LCD shows up the car's current status and the interior temp of the car and sounds melody. For example, the  shows the Celsius temp. Of interior of the car °
- Note: The temp. Indication on the LCD can be programmed into Celsius or Fahrenheit mode as required. [RF features programmable].



## 15. Active channel # 1 for release trunk

1. Whether the main system is in lock/arm or unlock/disarm modes, remote trunk release can be done using this channel (The car must have electronic trunk release).
2. Press and hold **【 III 】** simultaneously to remote release the trunk. Parking light 3 times flashes.
  - 1 If trunk open the remote LCD shows up the trunk release icon  along with the current status and sounds melody.

## 16. Remote Smart Siren alert ON/OFF

1. While the main system is in lock/arm mode: press and release **【 IV 】** to select the "Smart Siren" or mute alert modes.
2. If system "Smart Siren" choice:
  - 1) While the main system into arm the siren one chip to indicator. If siren chip 4 times the

mean's which zoom trigger.

- 2) While the main system into disarm the siren on alert. If siren chips 4 times the mean's which zoom trigger by arm time.
- 1 The remote LCD responses as below:
3. If the audible alert mode is chosen, the remote LCD shows  and sounds melody.
4. If the mute alert mode is chosen, the remote LCD shows  and sounds melody.

## 17. Active channel # 2

Press and hold **【IV】**:To active channel # 2 .The siren chirps with flashes of parking light.



## 18. Active channel # 3

1. If the main system is set at channel # 3 mode {additional accessory is required}.
2. Press and hold **【I】** The system will active channel # 3 output with parking light flash 3 times.  
The remote LCD shows up current car's status with 3 short beeps.

## 19. Car locator/search

1. Press and release both **【III+IV】** simultaneously: siren chirps 6 times with 6 flashes of parking light.
- 1 The remote LCD shows up the car's current status and sounds melody.

## 20. Shock sensor by pass

1. Whether in lock/arm or unlock/disarm modes.
2. This function can be activated to avoid false alarm especially when the car is parked in an area near a rail-line.
3. First press both and release both **【I + IV】** simultaneously the main system's shock sensor only first stage becomes ineffective.
4. Second press both and release both **【I + IV】** simultaneously the main system's shock sensor becomes ineffective. Other security functions lock/arm mode are operable.
5. During the system's arm mode, after the shock sensor is being triggered for 8 times: the system will bypass the shock sensor.
6. Press **【🔒】** button to get the inactive shock sensor into normal working mode again.
- 1 The remote LCD shows up  and  with one beep alert.

## 21. Alarm mode & warn away

1. In arm mode: If the car detects any impact; the shock sensor's first stage will be triggered. With 2 flashes of parking light.
- 1 The remote LCD shows up  with one long beep alert.
2. If the heavier impact is detected by the main system, the second stage shock sensor will

be triggered .The siren blurps for 15 sec with parking light flashing for the same time.

- 1 The remote LCD shows up  with beep alert for 15 sec.
3. If the trigger is generated by other means like door open, trunk/hood open or ignition "ON" under arm mode, the siren blurps 30 sec with parking light flashing for the same time and the engine start circuit is killed.
- 1 The remote LCD will show up icon of triggered zone and keep beeping for 30 sec.

Note:

4. While the alert are being triggered in arm mode, press and release **【I】** once to disable triggering. The 2<sup>nd</sup> press and release of **【I】** to make the main system enter unlock/disarm mode.
5. The main system will enter security mode during or after the triggered zone is closed. In case that the triggered zone is still open, the system will isolate it. But the system will still protect all other zones.

## 22. Remote Panic

When the engine shuts off; press and releaser both **【I + III】** simultaneously, the parking light flashes 3 times with siren chirps 3 times and auto enter arm/lock mode.

- 1 The remote LCD shows up current car's status and sounds melody.

## 23. Switch-controlled anti-hijack at standby mode

Active anti-hijack standby mode: While ignition is on. If push anti-hijack switch the system will get into the Anti-hi jack stand by mode.

Anti-hi jack standby mode : While the system in this mode with ignition still "ON", if the door is opened the system will get into anti-hijack stage. Refer 23 items.

Disabled anti-hijack standby mode: While the system in this mode, if the ignition is turned "OFF" this function will not be effective.

## 24. Remote or switch-controlled anti-hijack ON/OFF

1. While the engine is running; Press and hold both **【I + III】** simultaneously to activate this function or press the anti-hijack switch, to activate this function which is followed by 2 stages of active anti-hijack modes.
  - (A) In the 1<sup>st</sup> stage: the parking light flashes for 30 sec.
  - (B) In the 2<sup>nd</sup> stage; in the following 30 sec after the 1st stage, there will be additional 30 sec alert active mode during which **【(a) the parking light keeps on flashing (b) siren goes on blurping, (c) the engine start circuit is cut off till this active mode is deactivated】**
2. To deactivate any of the alert stage, press and hold for 5 sec the anti-hijack switch OR press on the remote unit AND press **【I】** again.
  - 1 The remote LCD shows up  and sounds alert beep.

## 25. Remote valet ON /OFF

1. Press and hold all **【II + III + IV】** simultaneously, to enter valet mode ON. The siren chirps 3 times with 2 flashes of parking light. During the valet ON mode, all functions are

inoperative except for the remote door open and trunk release, which remain operable.

2. Press and release all **【 II + III + IV 】** simultaneously to return to valet mode OFF and at the same time the main system restores all functions back to normal.
1. The remote LCD responses as below:
3. When the valet mode is switched ON, the LCD remote displays 『 Z<sup>2</sup> 』 and sounds melody.
4. When the Valet mode is switched off, the LCD remote does not display 『 Z<sup>2</sup> 』 but it sounds melody.

## 26. Page-out call

1. If pressed the page-out call button on vehicle-base antenna case parking light 3 times flashes
1. The LCD remote shows up 『 CALL 』 and sounds melody.

## 27. Programmable function by over-ride switch

Step 1 Turn the ignition OFF

Step 2 Press and release the over-ride switch 3 times to enter valet mode

Step 3 Turn the ignition ON.

Step 4 Press and release the over-ride 1 time to turn ON valet mode.

Repeat Step 1 to Step 4 to OFF Valet mode.

## 28. Manual Arm and Disarm (In case the remote transmitter is lost)

(a) Manual Arm:

1. Turn the ignition key to ON position. [Engine must not be running]
2. Press and release the over-ride switch 8 times
3. Turn the ignition key to OFF position {siren chirps 1 time with 1 flash of parking light} after 20 sec, the main system will enter ARM mode.

(b) Manual Disarm:

1. Turn the ignition key to ON position. [Engine must not be running]
2. Press and release the over-ride switch 4 times
3. Turn the ignition key to OFF position {siren chirps 2 times with 2 flashes of parking light}. The system will enter DISARM mode.
4. Under manual ARM mode: if the system is triggered, the system will enter initial alert mode (siren chirps 3 times with 3 flashes of parking light). 20 sec later, the system enters Alarm and Warn Away Mode. [The car owner can terminate the alarm trigger at this stage].
5. Under manual ARM or DISARM modes, all the system's features can still be operated by the remote transmitter.

## 29. How to learn codes of the remote transmitter

The main system can memorize transmitter's coding (from up to 4 different remote units)

1. Turn the ignition key to "ON" (Engine must not be running) Press and hold the over-ride switch for 6 sec and release it after the siren chirps 4 times which confirms the system has entered active learning mode.
2. Press and hold **【 III + IV 】** simultaneously till the siren chirps 1 time confirming code

learning is completed.

Follow the same step (2) with other remote transmitters, one after another, to allow the main system learn coding of each transmitter. (Maximum 4 remotes can be learned) .The system will automatically jump out of learning mode if no signal is received within 6 sec. from the last signal.

3. The pre-memorized coding will be erased each time the learning mode is activated. Re-do the code learning in this case.
4. If more than one remote are used in remote operating the same system, the car status will be displayed on the single remote, which sends the latest remote signal.

## 30. Hopping code transition

This system uses the transmission on hopping code technology, which is totally free from being counterfeited by code grabbers.

## 31. PIN Switch test for L E D

1. The system must be in disarm mode with the ignition ON
2. If all the switches are in good condition, opening of any of car door, trunk or hood can make the LED flash. The LED turns off when they are closed.

## 32. Dash LED status indicators

Fix the LED status indicator at the appropriate location inside the car to allow maximum visibility of it.

LED blinking pattern for various standby modes while ignition key is turned " OFF "	
Different standby modes	Pattern of LED blinking
The remote engine being started	L E D solid on
Alarm mode being cleared	No L E D light
Arm mode	* * * * *
Daily auto-start time ON	** ** ** ** **
Temp-controlled auto-start ON	*** **
Daily auto-start time ON + Temp- auto-start ON	**** **
Valet mode ON	***** **
LED blinking pattern with various standby modes while ignition " ON "	
Immobilize mode on	L E D solid on
Which PIN switch active	* * * * *

### 33. Power save mode of transmitter

If this mode is chosen  appears on the remote LCD: after 60 sec from the time of main systems disarm mode, the remote unit closes its reception circuit until any of the remote buttons is pressed. (Choice of this mode helps save remote unit's battery power and ensures long battery life.)

### 34. Low battery indicate

When  appears on the remote LCD, its battery is about to exhaust. Insert the new battery **【alkaline battery of size AAA is recommended】**

### 35. Out-of-range indication

When the remote's button is pressed. If the remote is out of range. The antenna  icon on the remote's LCD disappears.

### 36. Programming of remote control unit

The LCD remote control unit has basic features of (a) EL backlight (b) most power saving circuitry (c) audio or vibration alert mode (d) different time indication of **【 Real time, alarm clock, count-down timer】**

Operation of keys	Functions	Notes
<b>【F】</b>	Lamp ON (automatic turn-off after few sec)	
<b>【 I +F】</b>	Entry/exit of Power-saving mode	
<b>【 II +F】</b>	Choice of audible/vibration alert mode	
<b>【F】</b> Press and hold	Entry/exit of hour adjust mode	
<b>【F】</b> 1 time	Entry into minute adjust mode	Under any time adjustment mode: <b>【 III】</b> Press for upward adjustment or choice of ON mode <b>【 III】</b> Press and hold for quick upward adjustment <b>【 IV】</b> Press for downward or choice of "OFF" <b>【 IV】</b> Press and hold for quick downward adjustment
<b>【F】</b> 2 times	Alarm clock mode, by hour adjustment	
<b>【F】</b> 3 times	Alarm clock mode, by min adjustment	
<b>【F】</b> 4 times	Choice of ON/OFF for alarm clock mode	
<b>【F】</b> 5 times	Countdown mode, by hour adjustment	
<b>【F】</b> 6 times	Countdown mode, by min adjustment	
<b>【F】</b> 7 times	Choice for ON/OFF of countdown mode	
<b>【 III +F】</b>	Entry/exit of alarm adjust mode	
<b>【 IV +F】</b> 1 time	Choice of 10 min countdown mode	
<b>【 IV +F】</b> 2 times	Choice of 20 min countdown mode	
<b>【 IV +F】</b> 3 times	Choice of 30 min countdown mode	
<b>【 IV +F】</b> 4 times	Choice of 60 min countdown mode	
<b>【 IV +F】</b> 5 times	Choice of 90 min countdown mode	
<b>【 IV +F】</b> 6 times	Choice of 120 min countdown mode	

## ✂ Wire installation guide

The 2-way security system with remote engine starts features. While the system is action, the system's circuit interaction during remote controlling is the same situation with an ignition key. As the starter circuit differs depending on the car manufacturers, the main system's circuit must be verified before wiring.

### ATTENTION : Quick installation test

Before installation of the system, do this pre-test. See first if you can engine start with the ignition key without stepping on the accelerator. If engine start can be done this way, proceed with your installation. If not, check your car's engine and its carburetor system.

This system has a multitude of features and circuits that require a well-experienced installer's help. Installation of system with the remote engine start may pose some difficulty. To quickly find out technical problem of system with your car with auto transmission or manual transmission gear of gasoline cars, please follow these steps first to install a few assigned wires and see if remote engine start can be done. Then proceed with installation with the rest wires if the remote engine start can be done at this stage.

1. Get your car in neutral gear mode.
2. Complete wire connection of main unit H1 ignition harness with related wires of the car
3. Connect H3's PIN 1 & 16 to negative (-)
4. Connect H6 circuit with the car-base transceiver

Try to remote engine start with the remote unit and check if the remote engine start can work. Making sure that remote engine start can be done, re-install the 1<sup>st</sup> and 16<sup>th</sup> wires and all the rest wires according to the installation manual.

There is wrong wiring between the system's H1's wire and the ignition switch wire . You must refer to the installation manual carefully.

In the case that remote engine start cannot be done:

While trying to remote engine start, the dashboard panel illumines (in the same way when ignition key is being turned to ignition position) and system does cranking but the remote engine cannot be done. Below are the possible reasons.

1. If there is the immobilizer pre-installed
  - a) Insert the key and turn it at the "ACC" position and don't at ignition position
  - b) Try to remote start with the remote unit.
  - c) If the remote engine run can be done, it is clear that there is an immobilizer pre-installed On this car. Refer to the black/red wire of the 18PIN harness.
2. If three is the correct wiring of H1's ignition switch
  - a) Insert the key at the ignition switch OFF position and standby.
  - b) With the remote, try to remote engine start when dash board panel illumines by main unit and Immediately turn the ignition key to the "Ignition ON" position then main system will auto cranking.
  - c) If engine run can be done, the H1's wiring of the key switch is incorrect. Please carefully check H1's harness

✂ You are suggested to proceed with the rest installation only after such problems are solved

● H1 The 6 PIN main power harness wire:

1. Black w/ Yellow trace wire: output connecting wire for starter motor

This provides current to the start motor. Locate the wire of the ignition switch area that shows (+) 12 v when the ignition key is turned to “start” position. Connect this wire with the Black w/ Yellow trace wire.

2. Blue wire: output connecting wire for ACC

This provides the current needed by ACC. Locate the wire of the ignition switch area that shows (+) 12 v when the ignition key is turned to “ACC” and “ ignition” position . Connect this wire with the blue wire. But this wire must be “0” volts when the ignition key is turned to “ start” position.

3. Middle Red wire: + 12 v power source # 2.

This wire supplies power source for the main system.

4. Red wire: + 12 v power source # 1

Locate the 12v wire of the ignition switch and connect it with this. This supplies (+) 12V power with over 40 amps current ,regardless of position of the ignition key . This supplies power source for ACC, ignition # 1 , ignition # 2 , start wires and their relays.

5. Yellow wire: output connecting wire for ignition # 1

This provides the current required for the running of engine. Locate the wire of the ignition switch area that shows (+) 12 v when the ignition key is turned to “ignition” and “start” position. Connect this wire with the yellow wire.

6. Green wire: output connecting wire for ignition # 2

Locate the wire of the ignition switch area that shows (+) 12 v when the ignition key is turned to “ ignition” and “start” . Connect this wire with the green wire.

Note : In some vehicles, this wire shows “0” volts while the engine is starting or cranking. But in some vehicles, this provides +12 v current. Program this as required. [ Refer to RF Features Program Table 1, line 7th ] °

● H2 THE 6 PIN door lock/unlock harness

While the main system operates lock/unlock action . This harness controls internal relay “unlock ” and “lock ”.

※ Program the door lock/unlock output current time as required.[Refer to RF Features Program Table ,line 9<sup>th</sup> ]

\* Lock relay has wire connection as below:

1. PIN Blue wire is the Com. pin for terminal # 30 of the relay
2. PIN Blue w/gray wire is the N/O pin for terminal # 87 of the relay
3. PIN Blue w/black wire is the N/C pin for terminal # 87a of the relay

\* Unlock relay has wire connection as below:

4. PIN Green wire is the Com. pin for terminal # 30 of the relay
5. PIN Green w/gray wire is the N/O pin for terminal # 87 of the relay
6. PIN Green w/black wire is the N/C pin for terminal # 87a of the relay

● H3 THE 18 PIN input/output harness wire

※ 1 Black wire: ground input

Connect this wire to the ground. This is the ground wire for the main system.

3. Blue wire: Extra dome light device or window roll up module output 300ma (-)

Note1, 2 : for extra dome light device output pulse 20s or 30s after disarming and ignition turn off. This output can be active during alert signals, because in this case this output will be used for dome light.

Note3, 4 : for window output pulse 20s or 30s after arming. During 20s the shock sensor should be bypassed. This output can not be active during alert signals, because in this case this output will be used for windows closing. an additional close window module is required

[Refer to RF Features Program Table ,line 14<sup>th</sup> ]

## System dome light wire diagram

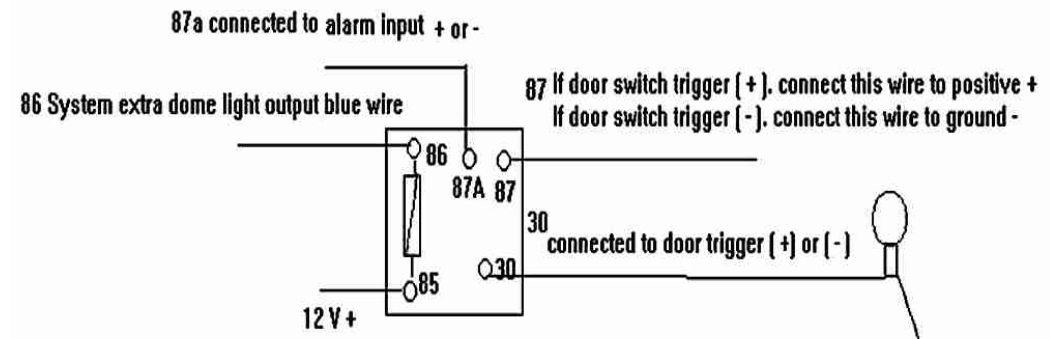

3 Black / Red wire: While remote start active output 300ma (-)

While the system is in remote engine start mode; this feeds (-) 300ma current.

1. With anti-theft controlled system vehicle, this circuit needs installation of additional accessory or relay to by-pass such immobilization

This does not need installation on the car without anti-theft chip.

4 Black/ Yellow wire: armed active output 300ma (-)

When the main system is armed and remote start engine running time this feeds (-)pulse of 300ma which, with the help of start killer relay, disrupt the current required for the starter motor. [ If start kill is in effect, the ignition key is unable to Start the engine] .The installing details is as below:

Note : To protect motor that might be damaged by start action with the ignition key while the engine is running by the remote control unit, additional start kill relay must be installed.

5 Yellow / Red wire: Active channel # 2 output 300ma (-)

When the remote transmitter activates this channel, this feed (-) 300ma output which, needs an additional relay, to control the device as required.

Note: Refer to RF Features Program Table , line 4<sup>th</sup> for programming.

※ 6. Grey / Black wire: voltage and tachometer or oil sensor device input ( signal )

The main system using which device to diagnosis the success of remote engine running.

(A) Didn't Connect Grey / Black wire :

The RF program time 4 need select at **【 I 】**:If the Grey/Black wire didn't connect any wire the system diagnosis the success of engine run only by voltage(Refer the dash LED shoes the LED 3<sup>rd</sup> indication mode).

(B) Connect Grey / Black to tachometer wire:

- 1) The RF program time 4 need select **【 I 】** or **【 II 】**: The Grey/Black wire need connect to tachometer device wire the system diagnosis the success of run depend RPM (Refer the dash LED shoes the LED 1<sup>st</sup> indication mode). If select at **【 II 】** and Grey/Black wire didn't connect any wire the system can't remote engine running successful.
- 2) The RF program time 4 need select at **【 III 】** the Grey/Black wire need connect to tachometer device wire second system need to do RPM learning procedure. If select at **【 II 】** but didn't RPM learning procedure the system can't allow remote start. Refer below note
- 3) The system diagnosis the success of run depend RPM (Refer the dash LED shoes the LED 1<sup>st</sup> indication mode). If select at **【 III 】** and Grey/Black wire didn't connect any wire the system can't remote engine running.

(C)Connect Grey / Black to oil sensor wire:

The RF program time 4 need select at **【 IV 】**4: The Grey/Black wire need connect to oil sensor device wire the system diagnosis the success of run depend it. (Refer the dash LED shoes the LED 3<sup>rd</sup> indication mode) If select at **【 IV 】**and Grey/Black wire didn't connect device the system can't remote engine running successful.

Note: Diagnosis signal form by tachometer device : During the remote engine start, if the system keeps cranking and will not stop even after engine run , the system apparently cannot diagnose TACH signal (Refer the dash LED shoes the LED 2<sup>nd</sup> indication mode). In this case, the system must do "learn TACH" procedure. Select The RF program time 4: have to select at **【 III 】** to RPM learn mode and have to make learn TACH" procedure If didn't make learn procedure that the remote start function becomes ineffective.

● The system requires TACH learning if RPM learn has to be chosen.

TACH mode Learning procedure

- 1) First turn off the power of all the electrical equipments like air-condition, ventilator.
- 2) Turn the ignition ON and then press the over-ride switch 9 times.
- 3) Turn the ignition OFF again. The status LED flashes 9 times and /or the siren sounds 9 chirps.
- 4) Start the engine with the key and allow the engine to idle first (dash LED will turn on ). When the tachometer indicates 500-1200 RPM (slowly running) revolution level, the engine gets warm up enough and proceed to step 5.
- 5) Press and hold the over-ride switch one time. The system's learning of proper TACH. is completed if the siren sounds 1 chirp. But if the siren sounds 4 chirps, the system fails to learn proper TACH and re-learning is required.

● Dash LED indication main system detect which signal for crank

**【 Only within 5 sec at the end of remote start cranking 】**

1. LED 1<sup>st</sup> indication mode ( the LED stays ON):  
The engine cranking stops immediately after engine run successfully neglecting the remaining crank time.
2. LED 2<sup>nd</sup> indication mode (the LED stays ON):  
The engine cranking will not stops immediately after engine run successfully depend on remaining crank time. In this case, the main system has to do TACH. mode learning procedure. When the TACH mode learning is successfully done, the LED indication will be the same as in the LED 1<sup>st</sup> indication mode.
3. LED 3<sup>rd</sup> indication mode ( the LED does not light ON):  
The engine cranking will not stops immediately after engine run successfully depend on remaining crank time. This means the main system makes use of generator or oil sensor light to diagnose the engine run success.
7. Blue/ Red wire: door switch positive trigger input (+)  
If the door switch is (+) trigger, connect this with the Blue/ Red trace wire. If the door is (-) trigger, leave the Blue / Red trace wire unconnected.
8. Orange / White wire: trunk switch negative trigger input (-)  
If the trunk switch is (-) trigger, connect trunk switch pin with the orange / white wire.
9. Purple wire: Anti-hijack switch for input (-)  
This provide (-) input for the switch-controlled anti-hijack function. If this wire gets the (-) input while the engine is running , the main system will enter anti-hijack mode
10. Green / Black wire: parking light output 7.5 A(+)  
While the system is in action, the main system feeds, through onboard relay, different times of (+) 12 v current for lamp signal. Locate the left or right parking light wire from the direction indicator switch and connect it.  
\* Both wires of left and right parking light from direction indicator switch must have positive output.
11. Green/ Yellow wire: parking light output 7.5 A(+)  
While the system is in action, the main system feeds, through onboard relay, different times of (+) 12 v current for lamp signal. Locate the left or right parking light wire from the direction indicator switch and connect it.  
\* Both wires of left and right parking light from direction indicator switch must have positive output.
12. Black/ White wire: Disarm active output 300ma (-)  
This feeds negative output at normal time. But during arm mode or remote engine start or immobilize mode, this stops any output and with the additional relay it disables ignition coil.  
(Refer to the 15<sup>th</sup> features option on RF program table)
13. Grey wire: Siren output 1. 5 A(+)  
For different action by main system; the main system feeds different (+) 12v for alert signal. Connect this wire with the red wire of the siren or use an additional relay to connect with the original horn.  
(Refer to RF Features Program Table , line 6th )

14. Yellow/ Blue wire: Active channel #3 output or 2 step door unlock output 300ma (-)  
One of the options can be chosen as required. (a) active channel # 3 and (b) 2 stage door unlock [ for 1<sup>st</sup> stage to open the driver's door and for 2<sup>nd</sup> stage to open all other doors].

(A) active channel # 3:

If this option is chosen, when the remote transmitter activates this channel, it feeds (-) 300ma pulse current whose pulse time can be programmed. An additional accessory is required for the control of other device.

Note: Refer RF Features Program Table, line & 5<sup>th</sup> for pulse time programming.

(B) 2 stage door unlock:

If this option is chosen, when the remote transmitter activates this channel, it feeds (-) 300ma pulse current whose pulse timing can be programmed. An additional relay is required for the control of door lock/unlock .

Note: Program it as required by referring to RF Features Program Table ,line 10<sup>th</sup>

15. Yellow / Black wire: Active channel # 1 for trunk release output 300ma (-)

When remote activates this channel it feeds 1 sec. (-) 300ma current output. An additional relay is required for the trunk release. With addition of external relay, this wire can be used for trunk release. But the vehicle must have motor for trunk release.

16. Orange/violet wire: Rear brake light switch (or) hand brake switch input (-)

If wire connection is not done accordingly as below, remote engine cannot be done. There must be a negative current during the remote engine starting for the main system to allow for the remote engine start. While starting the engine remotely , if there is not any negative current on this wire the engine immediately shuts down. There are 2 options for this wire connection.

(A) Connect this wire with the wire of rear brake light (whose wire has negative current if the pedal brake is not used because of the current loop from the rear brake light). The current of rear brake light turns positive when the brake pedal is pressed

(B) Connect this wire with the wire from hand brake( i.e hand brake switch ) which has negative current if the hand brake is pulled up. The hand brake wire becomes positive if it is depressed. An diode needs to be installed during installation as in the diagram below.

17. Blue / Black wire: door switch negative trigger input (-)

If door switch is (-) trigger output, connect this door switch with blue/ black wire. But for door switch with (+) trigger output, leave the Blue w/black wire unconnected.

18. Orange / Gray wire: hood switch negative trigger input (-)

Connect the orange/ gray trace wire with hood switch's output wire. When the hood is closed this wire provides "0" current and the main system allows engine start. When the hood is opened, this wire feeds (-) output. The main system will not allow engine start.

● H4 4 S black PIN shock sensor harness

1. White wire: (-) trigger wire for heavy impact
2. Blue wire: (-) trigger wire for light impact
3. Black wire: Neutral at normal time but feeds negative output during arm mode
4. Red wire: (+) 12V current for shock sensor power source

● H5 2 SS PIN over switch

1. Grey wire: over-ride switch input
2. Black wire: override switch ground output

● H6 2 S PIN LED

1. Red wire: LED (+) output
2. Black wire: LED (-) output

● H7 5 S dPIN RF transmitter case harness

1. Black wire: (+) 5 V DC for RF transmitter power source
2. Black wire: RF data input/output
3. Black wire: Ground
4. Black wire: (-) Output
5. Black wire: temperature sensor page-out call data (-) input

● H8 External wire loop of main module to differentiate gear modes





This is used in selecting manual or auto transmission gear mode.

✘ For auto gear mode : keep the wire loop intact.

✘ For manual gear mode : cut this wire loop

✘ RF Features Programming

- 1) Set the main system to the Disarm mode but in audible mode.
- 2) Turn the ignition "ON" ( Engine must not be running.)
- 3) Press and release the override switch 6 times.
- 4) Turn the ignition "OFF" {siren chirps 6 times confirming it has entered active programming mode}.
- 5) While in the active programming mode, each press on override switch is followed by one chirp and each fifth press is followed by a long chirp. Chirping pattern enables the programmer to know which features active mode he has achieved. Within 10 sec, change the default in each active feature mode by pressing assigned button.( as shown in the Default change by remote's button column). The factory default is described in the shaded background.

RF Features Program Table		Default change by remote's button			
Press times of override switch	RF features active mode with factory default	Press button  K I	Press button  K II	Press button  K III	Press button  K IV
01 time	Engine runtime upon remote start for 5/10/15/20 min	<input type="checkbox"/> 5 min	<input type="checkbox"/> 10 min	<input type="checkbox"/> 15 min	<input type="checkbox"/> 20 min
02 time	Temp-controlled engine start at -5°/-10°/-20°/-30°	<input type="checkbox"/> -5°C	<input type="checkbox"/> -10° C	<input type="checkbox"/> -20°C	<input type="checkbox"/> -30°C
03 time	Crank time for each start 800ms/1200/1800ms/3000ms	<input type="checkbox"/> 800ms	<input type="checkbox"/> 1200ms	<input type="checkbox"/> 1800ms	<input type="checkbox"/> 3000ms
04 time	Detect engine running by voltage/RPM /oil	<input type="checkbox"/> Voltage / RPM	<input type="checkbox"/> RPM	<input type="checkbox"/> RPM Learn	<input type="checkbox"/> OIL
05 time	CH # 3 output pulse time 0.8s/10s/30s/ and ON/OFF	<input type="checkbox"/> 0.8s	<input type="checkbox"/> 10s	<input type="checkbox"/> 30s	<input type="checkbox"/> On/Off
06 time	Siren or Horn choice	<input type="checkbox"/> 100ms	<input type="checkbox"/> 10ms Horn	<input type="checkbox"/> 15ms Horn	<input type="checkbox"/> 20ms Horn
07 time	Choice of ignition 2 wire output upon cranking	<input type="checkbox"/> ON	<input type="checkbox"/> ON	<input type="checkbox"/> ON	<input type="checkbox"/> ON
	Remote engine start with door auto lock /arm	Note1 OFF	Note2 OFF	Note3 OFF	Note4 OFF
08 time	Remote start relay 2/10sec. crank for gasoline or diesel engine	<input type="checkbox"/> Note 1 Gasoline 2 sec.	<input type="checkbox"/> Note 2 Diesel 10 sec.		
09 time	Central lock/unlock output time	<input type="checkbox"/> Note1 0.8s	<input type="checkbox"/> Note2 3.6s	<input type="checkbox"/> Note3	<input type="checkbox"/> Note4
10 time	Channel # 3 or 2 step door unlock	<input type="checkbox"/> CH#3	<input type="checkbox"/> 2step	<input type="checkbox"/> CH#3	<input type="checkbox"/> 2step
	Auto immobilized	Note1 OFF	Note2 OFF	Note3 ON	Note4 ON
11 time	Auto lock/unlock upon ignition on/off	<input type="checkbox"/> Note1	<input type="checkbox"/> Note2 1sec. lock	<input type="checkbox"/> Note3 10sec.lock	<input type="checkbox"/> Note4 OFF
12 time	Last door auto arm	<input type="checkbox"/> Note2 OFF	<input type="checkbox"/> Note2 without lock	<input type="checkbox"/> Note3 with lock	<input type="checkbox"/> Note4 OFF
13 time	Door input trigger function	<input type="checkbox"/> Dome light SB	<input type="checkbox"/> Dome light SB	<input type="checkbox"/> Door pin switch	<input type="checkbox"/> Door pin switch
	Remote start select for manual gear	Smart made	Safe mode	Smart made	Safe mode
14 time	Blue wire output for dome light or window roll up	<input type="checkbox"/> Note1 Dome light 20	<input type="checkbox"/> Note2 light 30 sec.	<input type="checkbox"/> Note3 window roll up	<input type="checkbox"/> Note4 window roll up
15 time	Remote LCD's temp. display mode of car (Celsius/ Fahrenheit)	<input type="checkbox"/> Note1 °C	<input type="checkbox"/> Note2 °F	<input type="checkbox"/> Note3 °C	<input type="checkbox"/> Note4 °F
	Black/ White wire active choice	N/O	N/C	N/C	N/C
16 time	Turbo engine timer	<input type="checkbox"/> OFF	<input type="checkbox"/> 1min	<input type="checkbox"/> 3min	<input type="checkbox"/> 6min

※ For future reference, installer is recommended to mark each box after selection of function mode.

### RF Features Program Table explanation

- Engine runtime upon remote start for 5/10/15/20 min :  
Choice of engine runtime after engine starting by remote unit.
- Temp-controlled engine start at -5°C/-10°C/-20°C/-30°C :  
If this feature is turned ON , the engine will auto start at the selected temp. and will be running at the pre-set run time ( Refer to time 1)
- Crank time for each remote start :  
Following each remote engine start, engine will crank for the 1st pre-set time. If engine fails to start after the 1<sup>st</sup> crank time, engine will try starting for the 2<sup>nd</sup> crank time (with extended 200ms add-up ) with total 4 cranking times. If the engine starts still fails after the 4<sup>th</sup> crank time, the system stops starting.  
※ Select 3000ms crank time if the main system has circuit connection with tachometer's RPM wire. ( Setting of 3000msa is a must in such case)
- Detect engine running by voltage/RPM /oil
  - Voltage /RPM: If select this mode engine running depend which device connect
  - RPM: If select this mode engine running only depend TACH.
  - RPM learn: If select this mode engine running only depend TACH. And system did learning procedure
  - OIL: If select this mode engine running only depend oil sensor.
- CH # 3 output time 0.8s/10s/30s/on.off : Choice of output pulse time of Active channel # 3.
- Siren or Horn chirp time choice:  
Remote control each time minimum chips time is 10ms with its maximum at 100ms. Any choice of such settings effects the pulse time when ARM /DISARM mode is done by a remote control unit. The pulse time varies depending on any of such settings and thus determines the volume of siren or horn.  
※ While the alarm run away function is activated, the pulse output may differ according to different settings as below:
  - If siren is set for 100ms, the pulse output continues for 30 sec.
  - If horn is set for any of Horn 1 10ms, Horn 2 15ms, Horn 3 20ms, the pulse output is intermittent for a duration of 30 sec during which pulse continues for 6 sec followed by 2 sec rest.
- Choice of ignition 2 wire output upon cranking and Remote engine start with door auto lock.  
Ignition # 2 Green wire output upon cranking: During cranking the ignition # 2 on some cars needs positive output to allow the remote engine start. But the same ignition # 2 of some cars do not need positive output to enable remote engine start . Programming is needed to select the outputs ON or OFF as required.  
Remote engine start with door auto lock: Select the auto door lock/unlock while remote engine start is done

Note 1: Ignition # 2 ON; remote engine start with door auto lock OFF  
 Note 2: Ignition # 2 OFF; remote engine start with door auto lock OFF  
 Note 3: Ignition # 2 ON; remote engine start with door auto lock ON  
 Note 4: Ignition # 2 OFF; remote engine start with door auto lock ON

8. Engine start delay of 2s/10s upon ignition: Choice for different fuel cars. Set the delay time of 2sec for gasoline car and set it at 10sec for diesel car which needs glow plug pre-heat.

Note 1: Choose this mode for gasoline car with each time 2sec start delay

Note2: Choose this mode for diesel car with each time 10 sec start delay:

9. Central lock/unlock output current time

Note 1: Lock - 0,8sec; Unlock - 0,8sec (for electric system)

Note 2: Lock - 3,6sec; Unlock - 3,6sec (for pneumatic system)

Note 3: Lock - 0,8sec; Unlock - 2 pulse of 0,8sec (for VW cars)

Note 4: Lock - 30sec; Unlock - 0,8sec ("comfort" output for Mercedes cars)

10. Channel # 3 or 2 step door unlock with Auto immobilized

If the 2 step door unlock is chosen, follow the wiring guide of door unlock/lock in the installation manual

Auto immobilized: While in the immobilize mode, immobilization is automatically activated after 30 sec from ignition OFF. The Black/ Yellow wire will active output negative.

Note 1: CH#3 with Auto immobilized OFF

Note 2: 2step door unlock with Auto immobilized OFF

Note 3: CH#3 with Auto immobilized ON

Note 4: 2step door unlock with Auto immobilized ON

11. Door lock/unlock on ignition :

Choice of door auto lock/unlock when the ignition is turned ON/OFF

Note 1. Door is not locked upon ignition is ON. It will immediately unlock when the ignition is OFF.

Note 2. Door is locked immediately upon ignition is ON. It will immediately unlock when the ignition is OFF.

Note 3. Door is locked 10 sec after the ignition is ON. It will immediately unlock when the ignition is OFF.

Note 4. Door is not locked/unlock upon ignition is ON/OFF.

12. Last door close with arm and lock :

Note 1: Last door close without arm

Note 2: Last door close only with arm without door lock

Note 3: Last door close with arm and Lock

Note 4: Last door close without arm

If Last door arm ON is chosen, whether the system is in Audible or Mute mode, the system will sound 1 beep to remind car owner after 10 sec when the system enters Auto rearm with auto door lock

( that follows Ignition Off and door lock)

※ If the car door is opened while the ignition is ON, the auto lock is disabled.

13. Into arm system's door zoom detect car's dome light or director door pin switch & Remote start select for manual gear Smart or Safe Mode.

1) Detect car's dome light wire "Smart Bypass": Which system into arm the door zoom detect effective will after the trigger disappear. If the trigger connection to 60 sec. the system will chips 4 times and the LCD show's door open. & for manual gear remote start with "Smart Mode".

2) Detect car's dome light wire "Smart Bypass": Which system into arm the door zoom detect effective will after the trigger disappear. If the trigger connection to 60 sec. the system will

chips 4 times and the LCD show's door open. & for manual gear remote start with "Safe Mode".

3) Director detect door "Pin Switch": Which system into arm the door zoom will immediate effective. Other word if into arm and door open the system will auto by pass siren chips and LCD show door open & for manual gear remote start with "Smart Mode".

4) Director detect door "Pin Switch": Which system into arm the door zoom will immediate effective. Other word if into arm and door open the system will auto by pass siren chips and LCD show door open & for manual gear remote start with "Safe Mode".

14. 2<sup>nd</sup> pin Blue wire output current time for dome light or window roll up

Note 1: for extra dome light device output pulse 20s after disarming. This output can be active during alert signals, because in this case this output will be used for dome light.

Note 2: for extra dome light device output pulse 30s after disarming. This output can be active during alert signals, because in this case this output will be used for dome light.

Note3: for window output pulse 20s after arming.

Note4: for window output pulse 30s after arming.

15. Remote LCD's temp. display mode of car (Celsius/ Fahrenheit) with Black/ White wire active choice

Note1: LCD's temp. display " C ".N/O Disarm and running time output negative

Note2: LCD's temp. display " F ".N/C Arm time output negative

Note3: LCD's temp. display " C ".N/C Arm time output negative

Note4: LCD's temp. display " F ".N/O Disarm and running time output negative

16. Turbo engine timer

Note 1: Choose this mode if the turbo timer is not needed.

Note 2: From the time ignition is turned "OFF" by key, engine will keep on running for 1 min. and turn itself off automatically.

Note 3: From the time ignition is turned "OFF" by key, engine will keep on running for 3 min and turn itself off automatically.

Note 4: From the time ignition is turned "OFF" by key, engine will keep on running for 6 min and turn itself off automatically.

※ How to restore RF Features to factory default settings.

Step (1). Turn the ignition ON ( Engine must not be running.)

Step (2) . Press the over-ride switch 10 times

Step (3). Turn the ignition OFF {Siren chirps 10 times, confirming the program active mode is initiated}.

Step (4) .Press override switch 1time which is followed by 1 siren chirp confirming the system has restored RF Features to the factory default settings.

Step (5). Press and release remote unit's button **【 I 】** which is followed by 1 buzz of remote unit to restore RF Features to factory default settings.

## H2 THE 6 PIN door lock/unlock harness

Installation differs depending on the car factory. Refer to one of the illus. below.

Wiring diagram (1) : The vehicle must have factory door lock relay control module and negative triggering

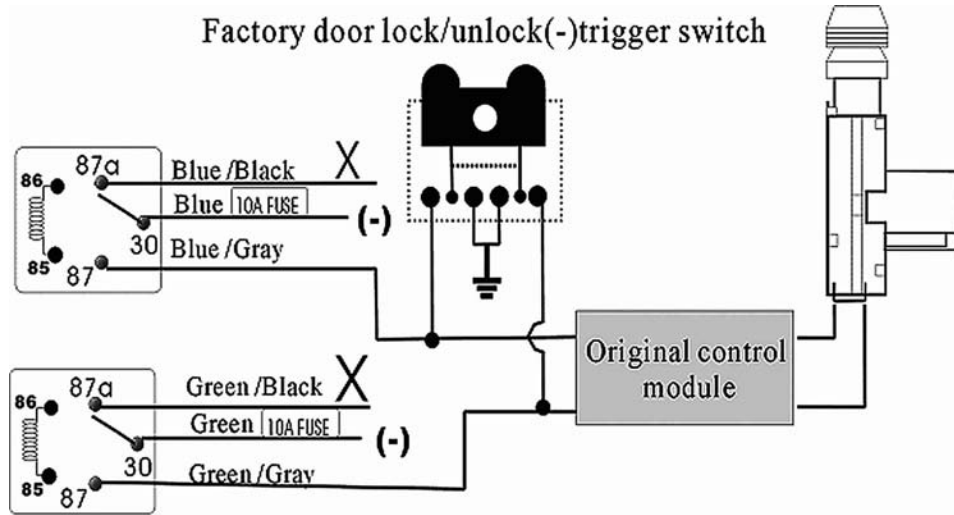

Wiring diagram (2) : The vehicle must have factory door lock relay control module and positive triggering

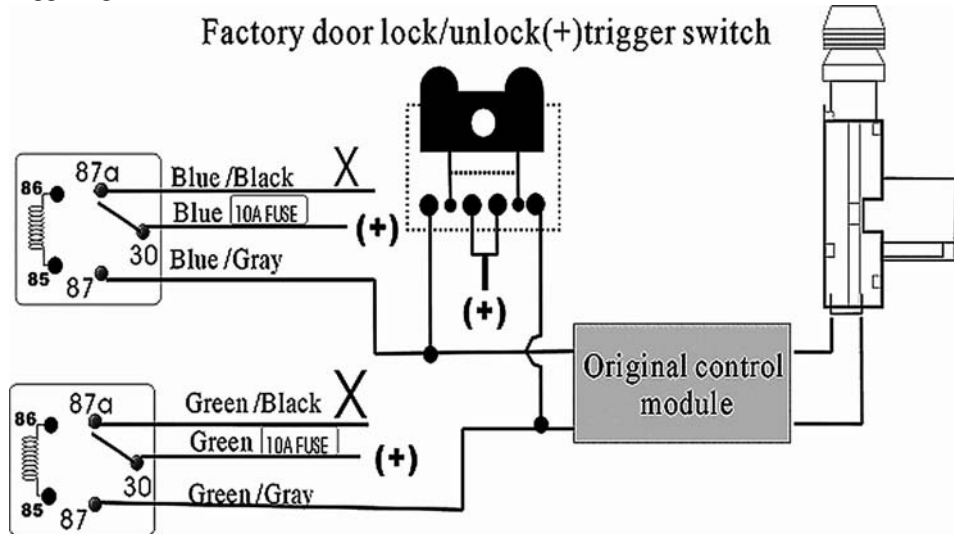

Wiring diagram (3) For the vehicle with pre-installed door lock relay control module which is fixed behind the control module

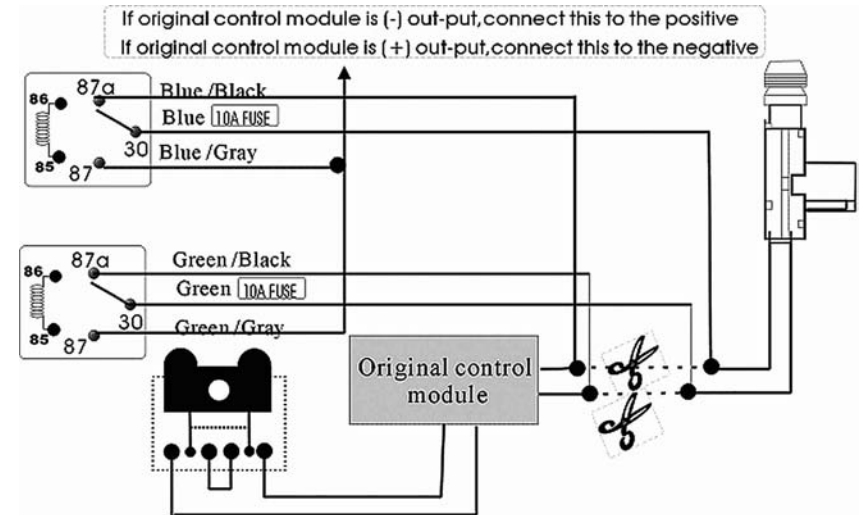

Wiring diagram (4) For vehicle without re-installed door lock relay control

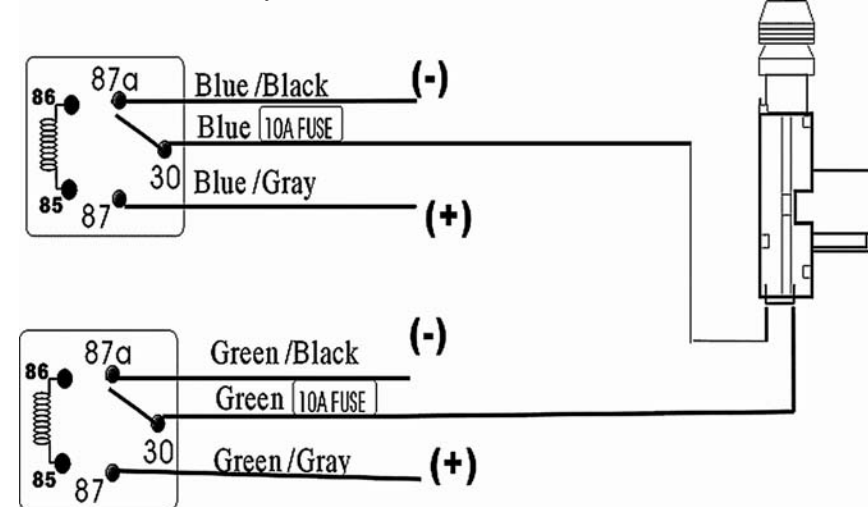

# WIRING DIAGRAM

Main Power Output VS IGN Switch Position				
Main wire	IGN Switch			
	OFF	ACC	IGN	START
RED	+	+	+	+
BLUE		+	+	
YELLOW			+	+
GREEN			+	○
BLACK/YELLOW				+

+ Positive pole  
○ Programmable as needed [Refer to RF Features Program Table]

